



DISTAL FIBULA SYSTEM

## **Distal Fibula Plating System**



**Surgical Technique**

**BIOMET®**



# A.L.P.S. Distal Fibula Plating System

---

## Contents

Surgeon Design Team .....	2
Introduction .....	3
Anatomic Fibula Locking Plate .....	10
Fibula Composite Locking Plate .....	11
Screw Specifications.....	12
Plates.....	13
Anatomic Plate Bending.....	14
Application of the Anatomic Plate.....	15
Composite Plate Bending .....	16
Application of the Composite Plate .....	17
Screw Insertion.....	18
Ordering Information .....	26



## Surgeon Design Team

George Haidukewych, M.D.  
Orlando Regional Medical Center  
Orlando Health, Inc.  
Orlando, Florida

David M. Huebner, M.D.  
Director of Orthopaedic Trauma,  
Good Samaritan Hospital,  
Kearney, Nebraska

Roy Sanders, M.D.  
Chief, Department of Orthopaedics,  
Tampa General Hospital,  
Director, Orthopaedic Trauma Services,  
Florida Orthopaedic Institute  
Tampa, Florida

Michael Wich, M.D.  
Deputy Head, Department of  
Trauma and Orthopaedic Surgery,  
Unfallkrankenhaus Berlin  
Berlin, Germany

# A.L.P.S. Distal Fibula Plating System

---

## Introduction

The A.L.P.S. Fibula plates represent the next generation in anatomic plate design. It combines the benefits of low profile titanium plate metallurgy with the advantages of multi-planar locked screw technology. These features allow the formation of a three dimensional matrix of fixed and variable angle screws to create a true subchondral scaffold

that can provide fixation in comminuted fractures or osteoporotic bone.

The A.L.P.S. Fibula plates feature TiMAX™ low profile, anatomically contoured implants. In distal fibula surgery where soft tissue coverage is at risk, these low profile plates are designed to minimize discomfort and soft tissue irritation matching the anatomy of the distal fibula, while still having the required strength.

These plates feature F.A.S.T. Guide® and Flexible Plating Technology to facilitate surgical procedures and save time in the operating room. F.A.S.T. Guide® inserts allow for accurate drilling and placement of screws. F.A.S.T. Guide® inserts are preloaded and do not require intraoperative assembly, resulting in significant time savings. These plates can also be customized intra-operatively to achieve an optimum anatomic fit.

Additionally, the A.L.P.S. Fibula plates allow the use of locking, variable angle, and standard screws. This hybrid fixation concept allows the surgeon to stabilize the fracture either by the use of lag screw techniques through the plate, or by compression plating techniques. Locking screws serve to provide stability to comminuted, unstable metaphyseal fractures or in osteopenic bone.

The A.L.P.S. Fibula Plating System is intended for the fixation of fractures, osteotomies and non-unions of the fibula, malleolus, distal tibia, metatarsals, scapula, clavicle, distal humerus and humeral head, olecranon, ulna, radius, and metacarpals, particularly in osteopenic bone.



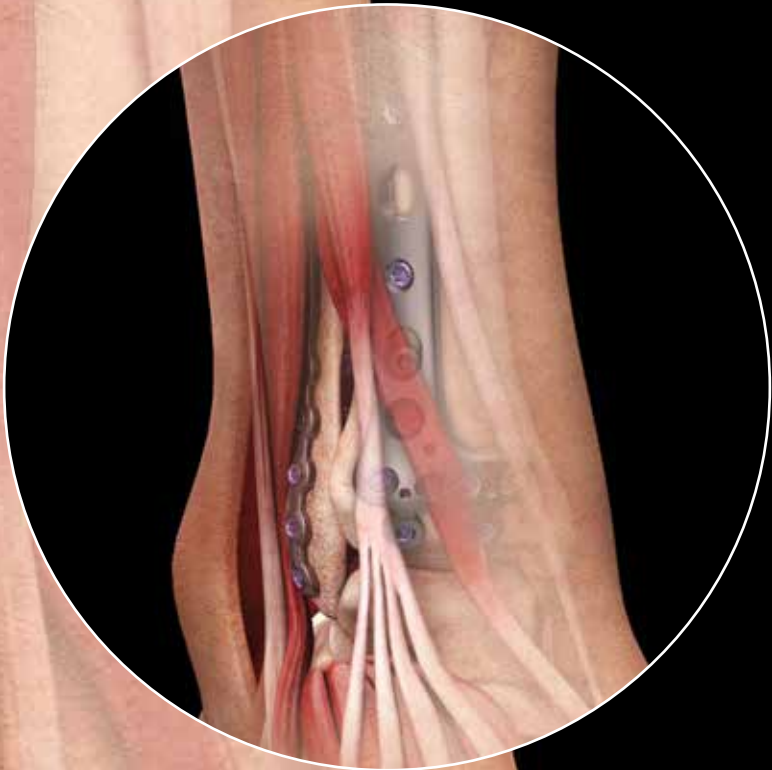

# A.L.P.S. Distal Fibula Plating System

---

## Low Profile Fibula Plates

- Anatomic fibula plate is pre-contoured to mimic the anatomy of the distal fibula for optimum bone conformance
- Composite locking plate combines the features of a locking compression plate and flexible plating technology
- Low profile helps minimize discomfort and soft tissue irritation
- Flexible plating technology delivers intra-operative customization
- Multiple sizes available to suit a wide variety of patients
- Engineered from TiMAX™ for strength, biocompatibility and enhanced imaging capabilities over stainless steel

For distal fibula procedures that often involve complex fractures and minimal tissue coverage, the A.L.P.S. Anatomic and Composite Locking Plates provide both strength and low-profile advantages. Having one of the slimmest profiles available and with the unique capability to contour in-situ, these plates may be used to treat even the most challenging cases.

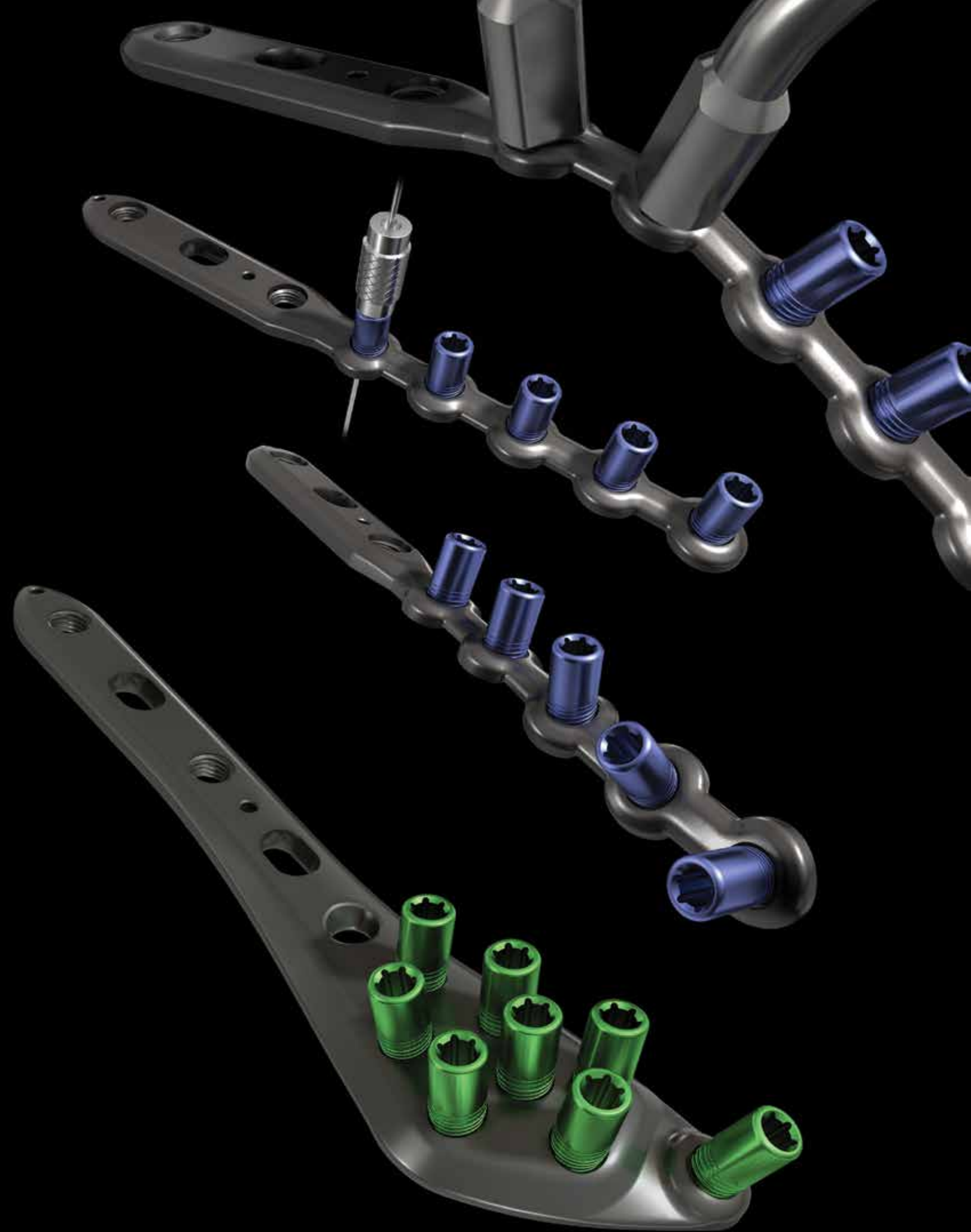



# A.L.P.S. Distal Fibula Plating System

---

Fast, Accurate Surgeries

## F.A.S.T. Guide® Technology

- Facilitate accurate drilling
- Pre-loaded and disposable
- Save time in the OR since no intra-operative assembly is required
- Color coded guides make identification easy:  
red guide = right, lime guide = left, blue guide = bilateral



## Intra-operative Customization

- Flexible plating technology delivers intra-operative customization
- Composite plates can be contoured in both coronal and axial planes

To facilitate surgical procedures even more, our Anatomic and Composite Fibula Plates come pre-loaded with Fixed Angle Screw Targeting (F.A.S.T.) Guides that direct the trajectory of the drill right into the plate.



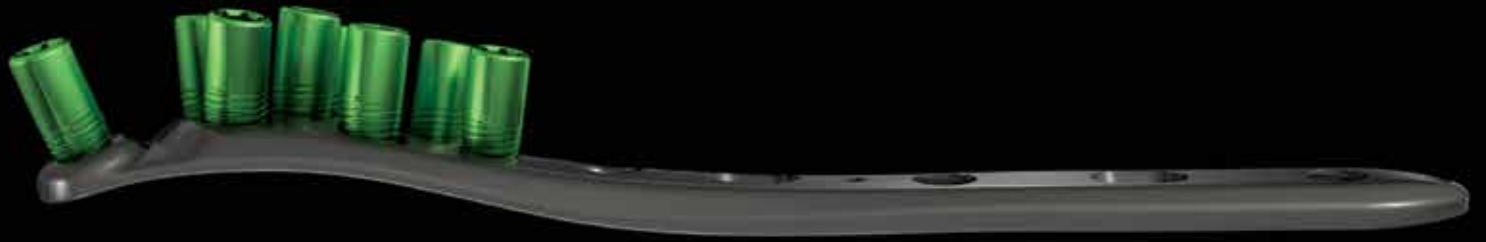

# A.L.P.S. Distal Fibula Plating System

---

## Versatility in Construct

### Locking, Non-Locking and Multi-Directional Screw Options

- Choose locking or non-locking screws, according to need
- Tapered, threaded screws lock into position when tightened to establish a fixed angle construct for strong fixation or when optimal screw purchase is required
- 3.5 mm low profile non-locking screws provide the same low profile design as locking screws for minimum soft tissue irritation
- Locking multi-directional screws (MDS) allow for up to 15 degrees of angulation from center for greater fixation

Particularly helpful in challenging fracture cases, the multiple screw options allow plates and screws to be placed as close to the bone surface as possible.

# A.L.P.S. Distal Fibula Plating System

## Anatomic Fibula Locking Plate



### Anatomical Fibula Locking Plate

Proximal Width	23.4 mm
Distal Width	10.0 mm
Proximal Thickness	2.8 mm
Distal Thickness	2.3 mm
Lengths	3H, 4H, 6H, 8H and 10H

# Fibula Composite Locking Plate

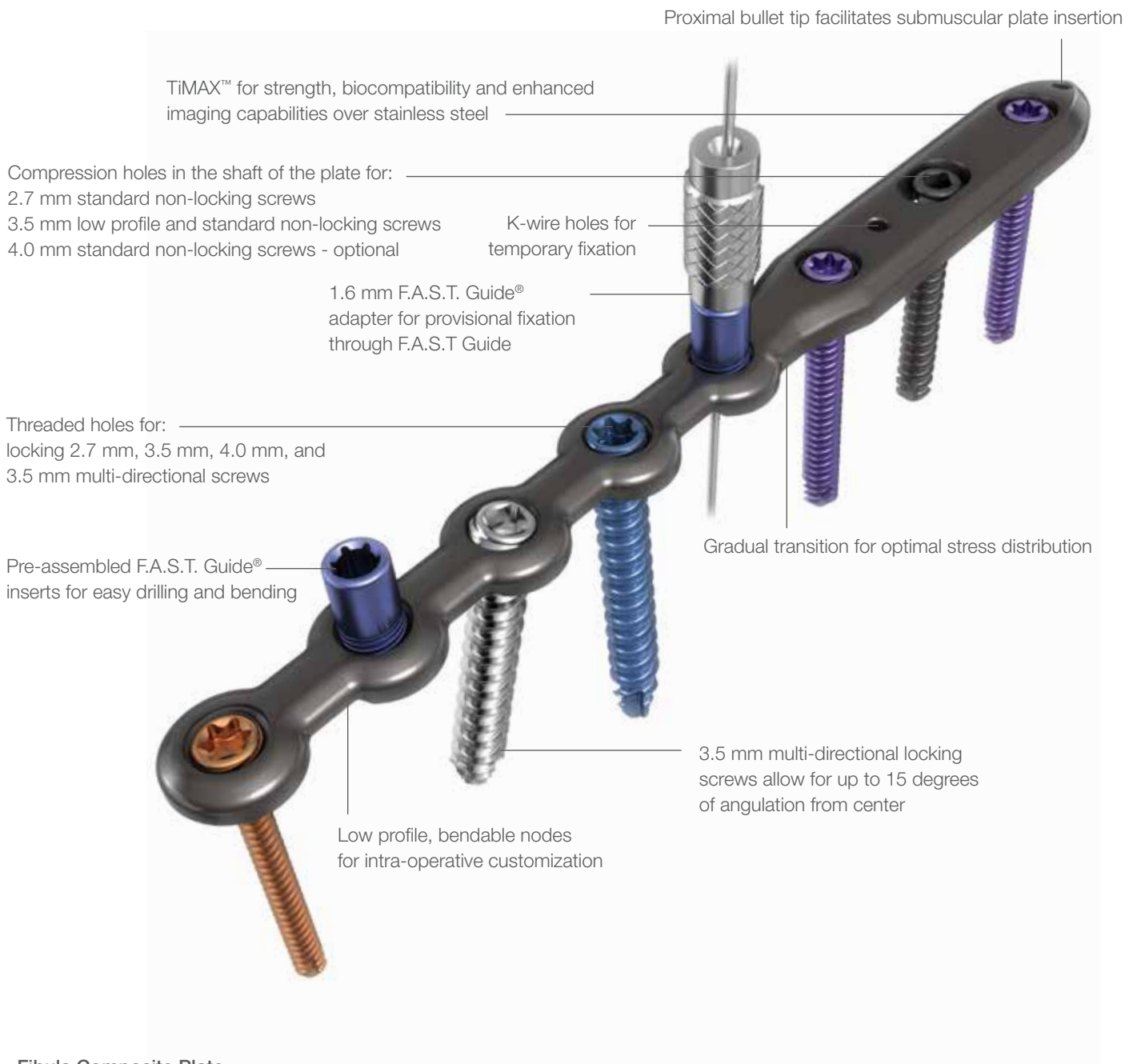

## Fibula Composite Plate

Proximal Width	10.0 mm
Distal Width	9.0 mm
Proximal Thickness	2.8 mm
Distal Thickness	1.9 mm
Lengths	6H, 7H, 8H, 10H, 12H and 14H

# A.L.P.S. Distal Fibula Plating System

## Screw Specifications

### 3.5 mm Low Profile Non-Locking Screw:

- Low profile head design reduces prominence beyond the plate
- Self tapping tip eases screw insertion
- Square drive for maximum torque delivery
- Type II anodized material for increased fatigue strength compared to standard titanium and stainless steel
- Screw (Cat. No.1312-18-0XX) uses a 2.5 mm Drill Bit (8290-29-070) and can be installed in any threaded or compression hole in the plate
- Available in lengths of 10 – 70 mm



### 2.7 mm Locking Cortical Screw:

- Self tapping tip minimizes the need for pre-tapping and eases screw insertion
- Tapered screw head helps ensure alignment of the screw head into the plate hole
- Tapered threaded head minimizes screw back-out and construct pullout
- T-15 drive
- Available in lengths of 10 – 50 mm
- Screw (8163-27-0XX) uses a 2.0 mm Marked Drill Bit (8163-01-009)



### 3.5 mm Locking Cortical Screw:

- Larger core diameter and shallower thread pitch for improved bending and shear strength compared to a standard 3.5 mm cortical screw
- Self tapping tip minimizes the need for pre-tapping and eases screw insertion
- Tapered screw head helps ensure alignment of the screw head into the plate hole
- Tapered threaded head minimizes screw back-out and construct pullout
- T-15 drive
- Available in lengths of 10 – 70 mm
- Screw (8161-35-0XX) uses a 2.7 mm Drill Bit (2142-27-070)



### 3.5 mm Locking Multi-Directional Screw:

- Cobalt-Chrome screw with large core diameter
- Multi-directional capability offers a 30 degree cone of angulation
- Creates own thread in plate to help provide strong and stable construct
- Screw head designed to prevent it from going through the threaded screw hole
- Self tapping tip minimizes the need for pre-tapping and eases screw insertion
- 2.2 mm square drive
- Available in lengths of 10 – 60 mm
- Screw (8163-35-0XX) uses a 2.7 mm Drill Bit (2142-27-070)



### 4.0 mm Locking Cancellous Screw:

- Self tapping tip minimizes the need for pre-tapping and eases screw insertion
- Tapered screw head helps ensure alignment of the screw head into the plate hole
- Tapered threaded head minimizes screw back-out and construct pullout
- T-15 drive
- Available in lengths of 10 – 70 mm
- Screw (8161-40-0XX) uses a 2.7 mm Drill Bit (2142-27-070)





# Plates

## Anatomic Fibula Locking Plate

(8162-0X-0XX)

The Anatomic Fibula Plate is a low profile, anatomically contoured plate, designed to fit on the lateral aspect of the distal fibula. These thin plates are designed to minimize discomfort and soft tissue irritation around the ankle, while still having the strength needed to achieve rigid fixation of the distal fibula fracture. All plates come with F.A.S.T. Guide® inserts inserted in the head portion for accurate drilling and placement of screws, with locking, lagging, or variable angle screw options available in the same construct (Figure 1).

These plates are pre-contoured and need little, if any, secondary adjustments to their shape. A contourable F.A.S.T. Tab with a threaded screw hole is present distally to lock small distal fragments to the plate. This tab is adjustable with Composite Plate Benders that fit over the F.A.S.T. Guide® inserts for easy and secure control. Contouring can be performed before application, or in situ.

## Fibula Composite Locking Plate

(8162-04-0XX)

The Fibula Composite Plate is a low profile plate that combines the features of a locking compression plate with flexible plating technology. These thin plates are designed to minimize discomfort and soft tissue irritation around the ankle, while still having the strength needed to achieve rigid fixation of the fibula fracture. All plates come with F.A.S.T. Guide® inserts for accurate drilling and placement of screws, with locking, lagging, or variable angle screw options available in the same construct (Figure 2).

These plates provide the flexibility of in-situ contourability to mimic the patient's natural anatomy. Contourable plate nodes with threaded screw holes are present distally to lock small distal fragments to the plate. These locking and non-locking plate nodes are adjustable in the coronal and axial planes and are contourable with Composite Plate Benders that fit over the F.A.S.T. Guide® inserts for easy and secure control. Contouring can be performed before application, or in situ.

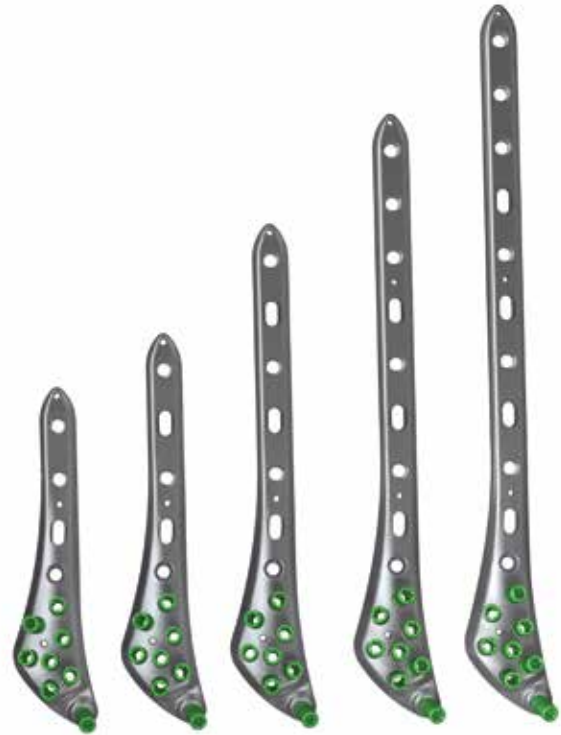

Figure 1

Anatomic Fibula Locking Plate Range available in left and right configurations.

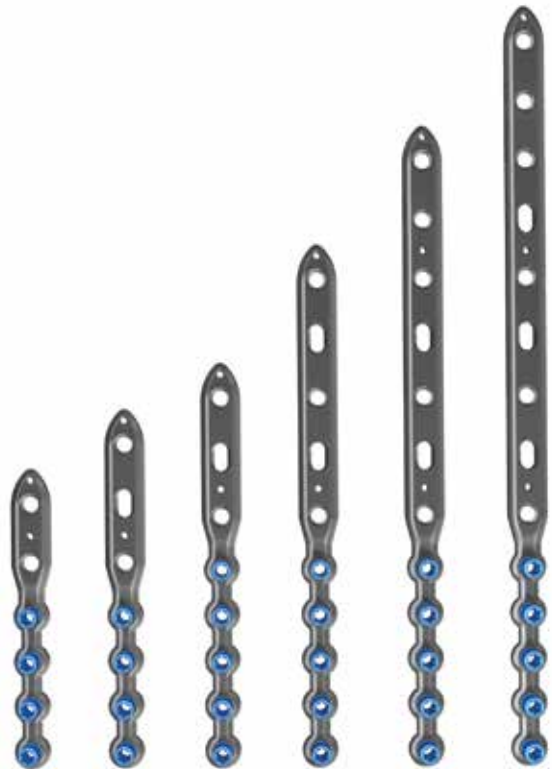

Figure 2

Fibula Composite Locking Plate Range.

# A.L.P.S. Distal Fibula Plating System

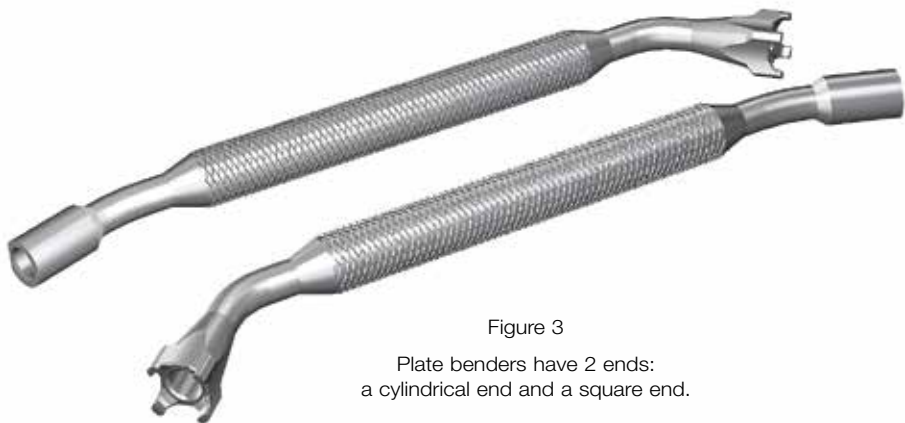

Figure 3

Plate benders have 2 ends:  
a cylindrical end and a square end.

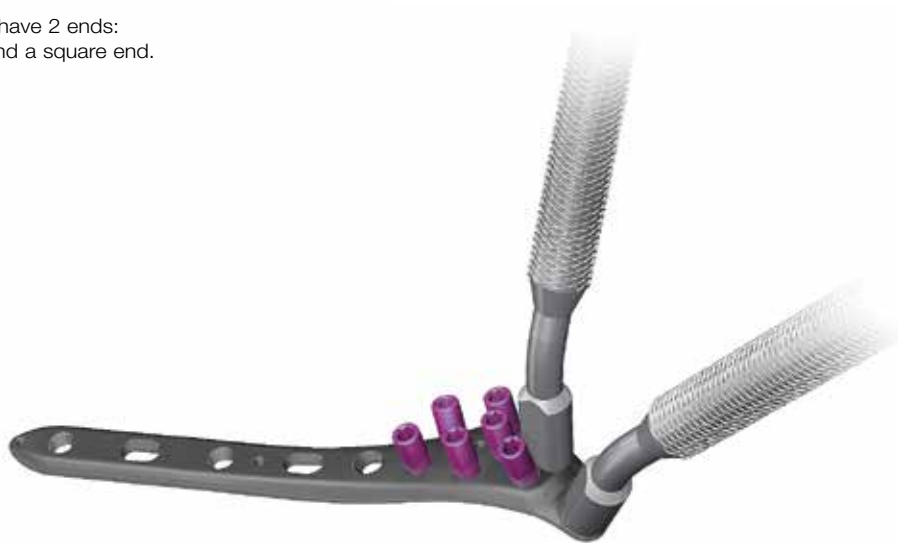

Figure 4

Plate can be shaped using the benders over the F.A.S.T. Guide® inserts.

## Anatomic Fibula Plate Bending

In most cases the pre-contoured plate will fit without the need for further bending. The distal tab may be contoured as needed using F.A.S.T. Guide® inserts and Composite Plate Benders (8163-01-017). To contour the F.A.S.T. Tab, place the cylindrical ends of the benders over opposing F.A.S.T. Guide® inserts and exert pressure on the distal bender until the desired contour is achieved (Figures 3 and 4).

Plates can be contoured outside the patient or intra-operatively. If the plate is contoured intra-operatively, then a 3.5 mm non-locking screw should be used in either a non-locking or locking hole to secure the plate to the bone.

**Note: Bending the distal tab beyond 20 degrees may result in breakage. Continuous bending will also fatigue the tab and cause it to break.**

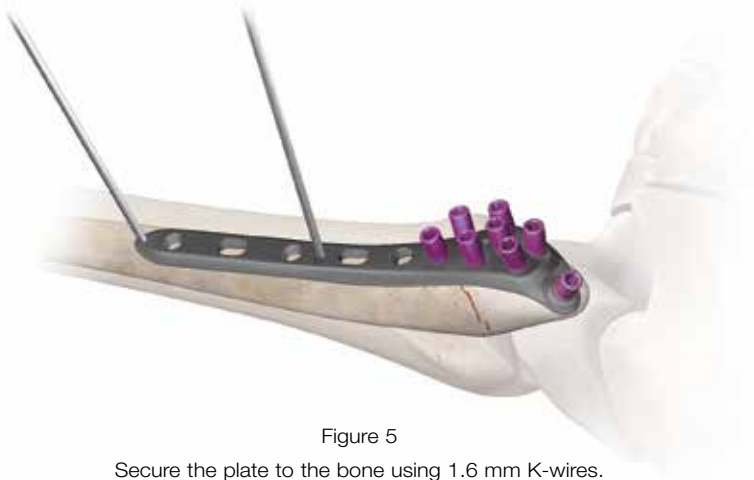

Figure 5

Secure the plate to the bone using 1.6 mm K-wires.



Figure 6

Use 1.6 mm F.A.S.T. Guide® Adapter and 1.6 mm K-wires to provisionally secure the plate to the bone.

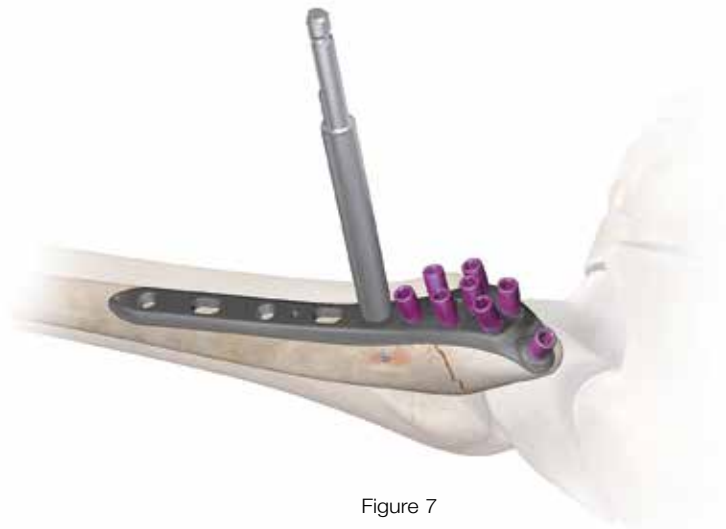

Figure 7

## Application of the Anatomic Plate

### Provisional Fixation

Once the fit of the Anatomic Plate has been confirmed both visually and fluoroscopically, 1.6 mm K-wires can be placed into the proximal K-wire holes to secure the plate to the bone (Figure 5).

Additionally, a 1.6 mm F.A.S.T. Guide® Adapter (2312-18-015) can be inserted into a F.A.S.T. Guide® insert to accept a 1.6 mm K-wire (Figure 6).

A provisional Fixation Pin (8242-99-000/1) may also be used to secure the plate temporarily.

The pin has a self-drilling tip and an AO quick connection for power insertion. Advance the pin slowly until the shoulder of the pin contacts the plate and pulls the plate down to the bone. Avoid advancing the pin beyond this point to prevent stripping of threads (Figure 7).

# A.L.P.S. Distal Fibula Plating System



Figure 8

Use the cylindrical ends of the benders to achieve single plane bending.



Figure 9

The plates can be contoured up to 45 degrees at each bridge between the F.A.S.T. Guide® inserts.

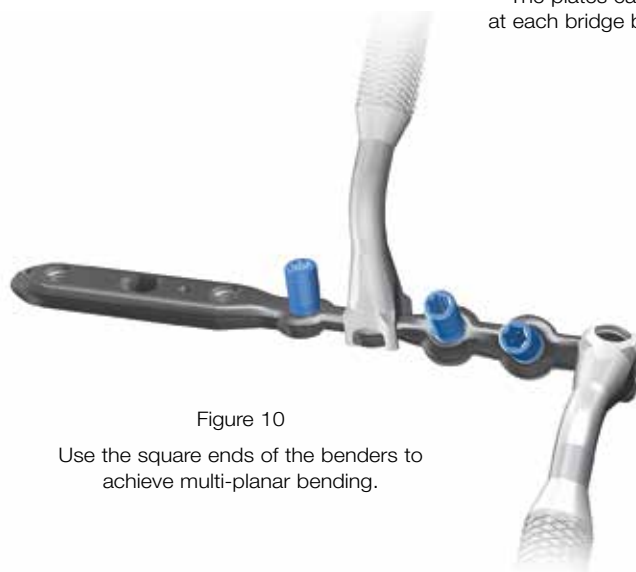

Figure 10

Use the square ends of the benders to achieve multi-planar bending.

## Composite Plate Bending

Plates can be contoured to achieve an anatomic fit by utilizing the F.A.S.T. Guide® inserts and Composite Plate Benders (8163-01-017). Use the cylindrical ends of the benders to achieve single plane bending. To contour the plate in the coronal plane by bending the plate toward the user (Figure 8) or away from the user (Figure 9), place the cylindrical ends of the benders over the F.A.S.T. Guide® inserts and hold one bender as an anchor and manipulate with the other. The plates can be contoured up to 45 degrees at each bridge between the F.A.S.T. Guide® inserts.

Use the square ends of the benders to achieve multi-planar bending. To contour the plate axially or to achieve

a twist shape (Figure 10), place the square ends of the benders over the F.A.S.T. Guide® inserts and hold one bender as an anchor and manipulate with the other. The plates can be contoured up to 45 degrees at each bridge between the F.A.S.T. Guide® inserts.

Plates can be contoured outside the patient or intra-operatively. If the plate is contoured intra-operatively, then a 3.5 mm non-locking screw should be used in either a non-locking or locking hole to secure the plate to the bone.

**Note: Bending the distal tab beyond 45 degrees may result in breakage. Continuous bending will also fatigue the tab and cause it to break.**

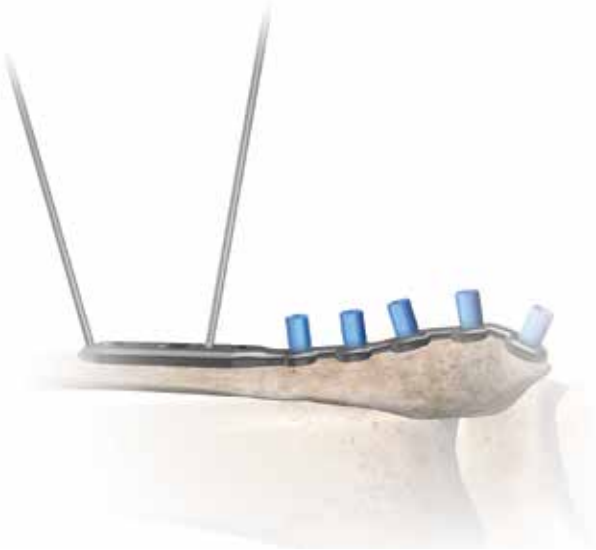

Figure 11

Secure the plate to the bone using 1.6 mm K-wires.

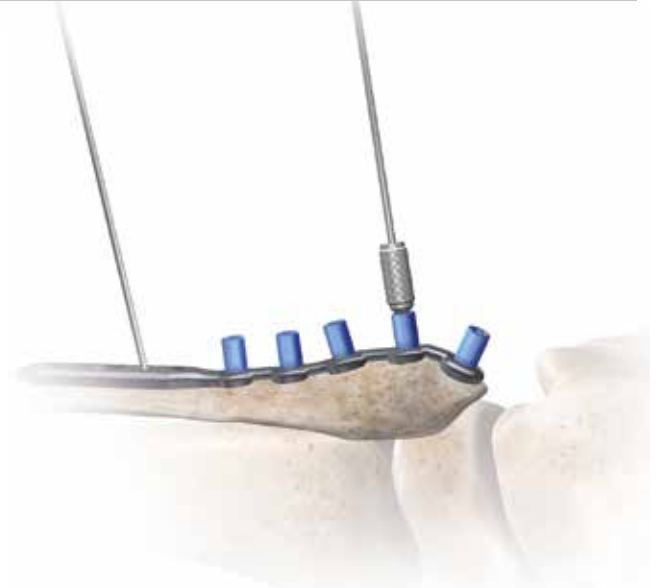

Figure 12

Use 1.6 mm F.A.S.T. Guide® Adapter and 1.6 mm K-wires to provisionally secure plate to the bone.

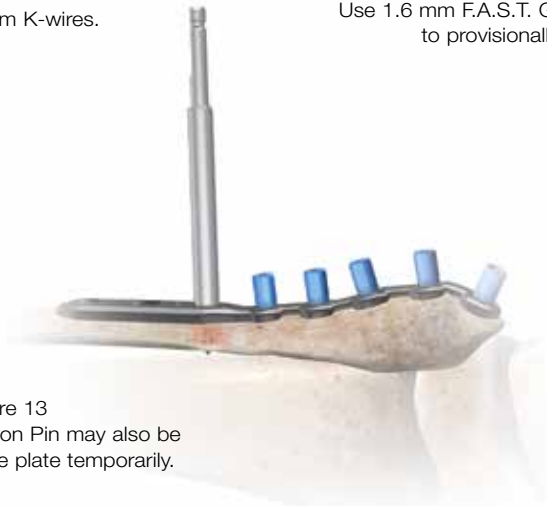

Figure 13

A provisional Fixation Pin may also be used to secure the plate temporarily.

## Application of the Composite Plate

### Provisional Fixation

Once the fit of the Composite Plate has been confirmed both visually and fluoroscopically, 1.6 mm K-wires can be placed into the proximal K-wire holes to secure the plate to the bone (Figure 11).

Additionally, a 1.6 mm F.A.S.T. Guide® Adapter (2312-18-015) can be inserted into a F.A.S.T. Guide® insert to accept a 1.6 mm K-wire (Figure 12).

A provisional Fixation Pin (8242-99-000/1) may also be used to secure the plate temporarily. The pin has a self-drilling tip and an AO quick connection for power insertion. Advance the pin slowly until the shoulder of the pin contacts the plate and pulls the plate down to the bone. Avoid advancing the pin beyond this point to prevent stripping of threads (Figure 13).

# A.L.P.S. Distal Fibula Plating System



Figure 14

Drill with the 2.0 mm Drill Bit through the 2.0/2.7 mm Drill Guide.

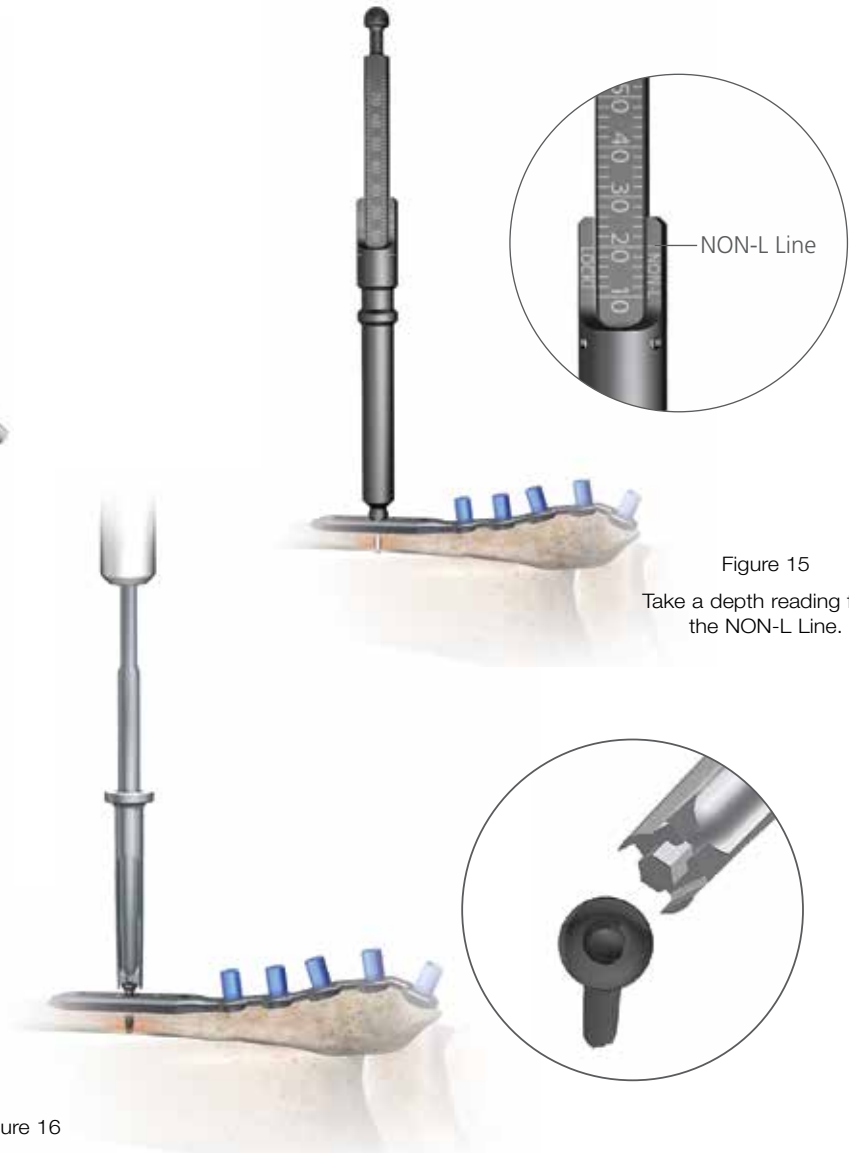

Figure 15

Take a depth reading from the NON-L Line.



Figure 16

Insert the 2.7 mm Non-Locking Cortical Screw using the 2.5 mm Hex Driver.

## Screw Insertion

The technique to insert screws onto the Anatomic and Composite plates is the same. Application of screws is shown on the Composite Plate. Insertion of a 2.7 mm Non-Locking Cortical Screw (8140-27-0XX) in a Compression or Threaded Hole.

Insert the 2.0 mm end of the 2.0/2.7 mm Drill Guide (9399-99-435) into the compression hole and drill through both cortices with the 2.0 mm Drill Bit (9399-99-382) (Figure 14).

Measure the drilled hole with the Small Fragment Depth Gauge (2142-35-100) (Figure 15) by taking a direct reading from the NON-L line.

Insert the appropriate length 2.7 mm Non-Locking Cortical Screw with the Screw Holder Sleeve (8241-66-000) over the 2.5 mm Hex Driver (8241-57-071) coupled to the Ratchet Handle (8261-66-000) (Figure 16).

**Note: For flush seating of the plate against the bone, use a non-locking screw prior to inserting a locked screw. If a non-locking screw is used in the distal part of the plate, then that F.A.S.T. Guide® insert needs to be removed prior to drilling.**





Figure 17

Drill with the 2.5 mm Drill Bit through the 2.5/3.5 mm Drill Guide.

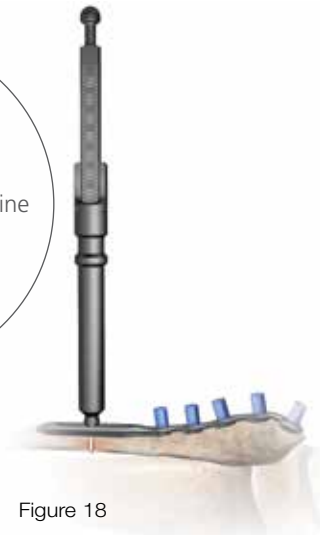
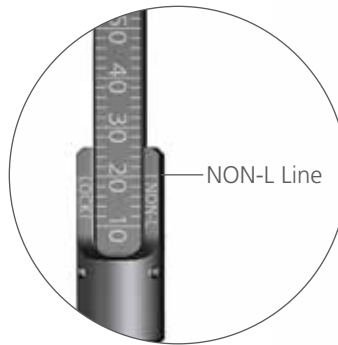

Figure 18

Take a depth reading from the NON-L Line.



Figure 19

Insert the 3.5 mm Non-Locking Cortical Screw using the 2.5 mm Hex Driver.



Figure 20

Insert the low profile 3.5 mm Non-Locking Cortical Screw using the 2.2 mm Square Driver coupled to the Ratchet Handle.

## Insertion of a 3.5 mm Non-Locking Cortical Screw in a Compression or Threaded Hole.

Insert the 2.5 mm end of the 2.5/3.5 mm Drill Guide (8241-96-000) into the threaded or compression hole and drill through both cortices with the 2.5 mm Drill Bit (8290-29-070) (Figure 17).

Measure the drilled hole with the Small Fragment Depth Gauge (2142-35-100) (Figure 18) by taking a direct reading from the NON-L line.

### 3.5 mm Standard Screw

Insert the appropriate length 3.5 mm Non-Locking Cortical Screw with the Screw Holder Sleeve (8241-66-000) over the 2.5 mm Hex Driver (8241-57-071) coupled to the Ratchet Handle (8261-66-000) (Figure 19).

### 3.5 mm Low Profile Screw

Insert the appropriate length 3.5 mm Low Profile Non-Locking Cortical Screw with the 2.2 mm Square Driver (8163-01-000) coupled to the Ratchet Handle (C8261-66-000) (Figure 20).

**Note:** For flush seating of the plate against the bone, use a non-locking screw prior to inserting a locked screw. If a non-locking screw is used in the distal part of the plate, then that F.A.S.T. Guide® insert needs to be removed prior to drilling.

# A.L.P.S. Distal Fibula Plating System



Figure 21

Slide the Measuring Drill Sleeve onto the 2.7 mm Drill Bit.

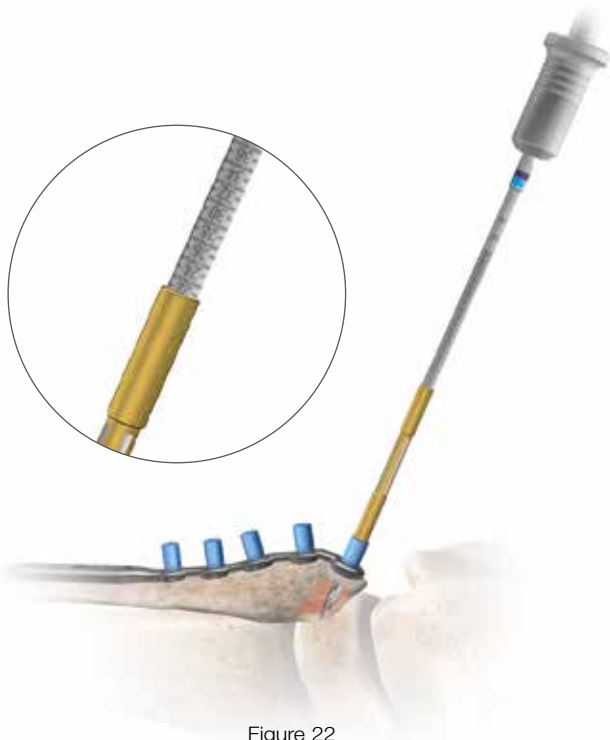

Figure 22



Figure 23

Insert the pre-determined Locking Screw using the T-15 Driver attached to the Torque-Limiting Driver Handle.

Slide the Measuring Drill Sleeve (8163-01-005) onto the 2.7 mm Drill Bit (2142-27-070) (Figure 21). Drill through the F.A.S.T. Guide® insert until the far cortex is reached. Slide the Measuring Drill Sleeve onto the top end of the F.A.S.T. Guide® insert and read the measurement of the Locking Screw length from the proximal end of the Drill Measuring Sleeve (Figure 22).

**Note:** If a second method of measurement is desired, remove the F.A.S.T. Guide® insert, then measure the drilled hole by taking a direct reading from the LOCK line on the Small Fragment Depth Gauge.

Next, remove the F.A.S.T. Guide® insert with the T-15 Driver (2142-15-070) that is attached to the Ratchet Handle (8261-66-000) and insert the pre-determined Locking Screw using the T-15 Driver that is attached to the 2.0 Nm Torque-Limiting Screwdriver Handle (2141-18-001) (Figure 23). This can also be done using the Torque Limiting Power Adapter (2312-18-020) to power in the locking screws.

**Tip:** If using power without a torque limiting power adapter, it should be at a slow speed. Perform all final screw tightening by hand with the Torque-Limiting Screwdriver.



Figure 24

Slide the 2.0 mm Measuring Drill Sleeve onto the 2.0 mm Drill Bit.

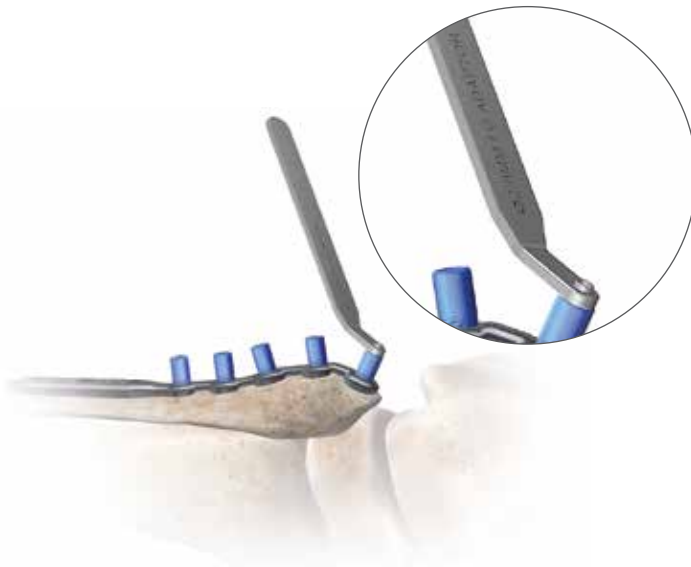

Figure 25

Place the 2.0 mm Converter Handle through the F.A.S.T. Guide® insert.

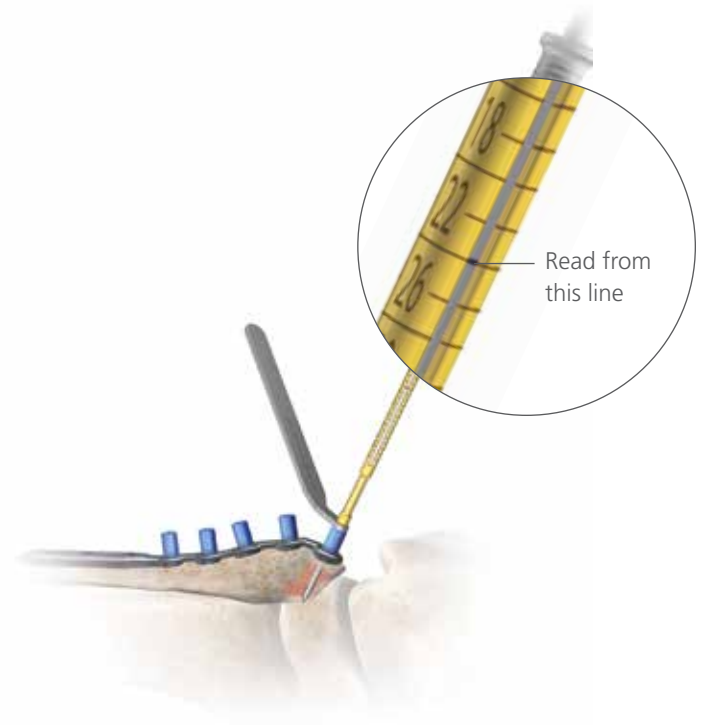

Figure 26

Drill through the F.A.S.T. Guide® insert with the 2.0 mm Drill Bit. Slide the Measuring Drill Sleeve to the top end of the Converter Handle and read the measurement of the Locking Screw length from the window.

### Insertion of a 2.7 mm Cortical Locking Screw (8163-27-0XX) into a Threaded Hole with a F.A.S.T. Guide® Insert.

Slide the 2.0 mm Measuring Drill Sleeve (8163-01-016) onto the 2.0 mm Marked Drill Bit (8163-01-009) (Figure 24). Place the 2.0 mm F.A.S.T. Guide® Converter Handle (2312-18-010) through the F.A.S.T. Guide® insert (Figure 25).

**Note:** If a second method of measurement is desired, remove the F.A.S.T. Guide® insert, then measure the drilled hole by taking a direct reading from the LOCK line on the Small Fragment Depth Gauge.

Drill through the F.A.S.T. Guide® insert until the far cortex is reached. Slide the 2.0 mm Measuring Drill Sleeve onto the top end of the 2.0 mm F.A.S.T. Guide® Converter Handle and read the measurement of the Locking Screw length from the window of the 2.0 mm Drill Measuring Sleeve (Figure 26).

# A.L.P.S. Distal Fibula Plating System



Figure 27

Insert the pre-determined Locking Screw using the T-15 Driver attached to the Torque-Limiting Driver Handle.



Figure 28

Insert 2.7 mm Locking Drill Guide, drill with the 2.7 mm Drill Bit, and read the depth from the top of the Drill Guide.

Next, remove the F.A.S.T. Guide® insert with the T-15 Driver (2142-15-070) that is attached to the Ratchet Handle (8261-66-000) and insert the pre-determined Locking Screw using the T-15 Driver that is attached to the 2.0 Nm Torque-Limiting Screwdriver Handle (2141-18-001) (Figure 27). This can also be done using the Torque Limiting Power Adapter (2312-18-020) to power in the locking screws.

**Tip:** If using power without a torque limiting power adapter, it should be at a slow speed. Perform all final screw tightening by hand with the Torque-Limiting Screwdriver.

The proximal end of the plate can now be secured to the bone. This can be achieved through the following options:

Insertion of a Locking Screw (3.5 mm Cortical 8161-35-0XX or 4.0 mm Cancellous 8161-40-0XX) in a Threaded Hole without a F.A.S.T. Guide® insert.

Screw the 2.7 mm Locking Drill Guide (2142-07-027) into a threaded plate hole until fully seated. Drill both cortices with the 2.7 mm Drill Bit to the desired depth and read the depth measurement from the drill bit at the top of the drill guide (Figure 28). Remove the 2.7 mm Locking Drill Guide.

# Screw Insertion

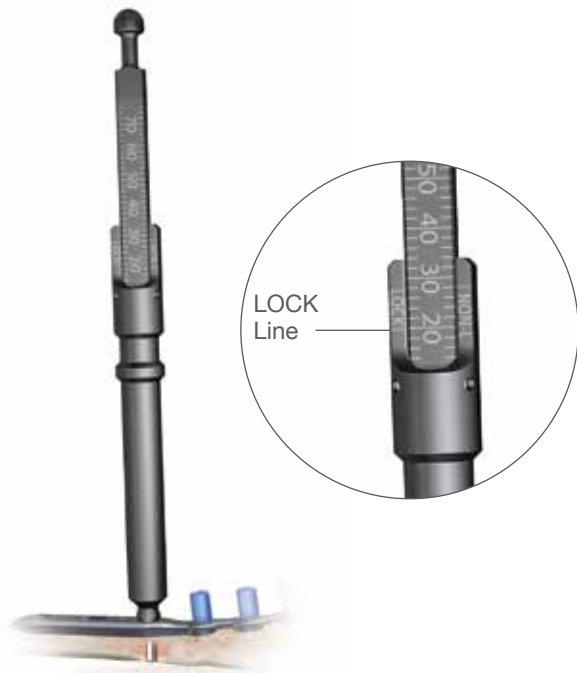

Figure 29

Take reading directly from the LOCK Line on the Small Fragment Depth Gauge.



Figure 30

Insert the Locking Screw using the T-15 Driver coupled to the Torque-Limiting Screwdriver Handle.

**Note:** If a second method of measurement is desired, remove the F.A.S.T. Guide® insert, then measure the drilled hole by taking a direct reading from the LOCK line on the Small Fragment Depth Gauge (Figure 29).

Insert the selected Locking Screw with the T-15 Driver (2142-15-070) coupled to the 2.0 Nm Torque-Limiting Screwdriver Handle (2142-18-001) (Figure 30).

This can also be done using the Torque Limiting Power Adapter (2312-18-020) to power in the locking screws.

**Tip:** If using power without a torque limiting power adapter, it should be at a slow speed. Perform all final screw tightening by hand with the Torque-Limiting Screwdriver.

# A.L.P.S. Distal Fibula Plating System



Figure 31

Insert 2.0 mm Locking Drill Guide and drill with the 2.0 mm Drill Bit.



Figure 32

Take reading directly from the LOCK Line on the Small Fragment Depth Gauge.



Figure 33

Insert the Locking Screw using the T-15 Driver coupled to the Torque-Limiting Screwdriver Handle.

Screw the 2.0 mm Locking Drill Guide (2142-07-020) into a threaded plate hole until fully seated. Drill both cortices with the 2.0 mm Marked Drill Bit (8163-01-009) to the desired depth (Figure 31). Remove the 2.0 mm Locking Drill Guide.

Measure the drilled hole with the Small Fragment Depth Gauge (2142-35-100) by taking a direct reading from the LOCK line (Figure 32) and insert the appropriate length 2.7 mm Locking Screw with the T-15 Driver (2142-15-070) that is attached to the 2.0 Nm Torque-Limiting Screwdriver Handle (2141-18-001) (Figure 33).

This can also be done using the Torque Limiting Power Adapter (2312-18-020) to power in the locking screws.

**Tip:** If using power without a torque limiting power adapter, it should be at a slow speed. Perform all final screw tightening by hand with the Torque-Limiting Screwdriver.



3.5 mm Multi-Directional Screws



Figure 34



Figure 35

Drill with the 2.7 mm Drill Bit through the 2.0/2.7 mm Drill Guide.



Figure 36

Take a direct reading from the LOCK Line on the Depth Gauge.



Figure 37

Insert the MDS screw using the 2.2 mm Square Driver coupled to the Ratchet Handle.

## Insertion of a 3.5 mm Multi-Directional Locking Screw in a Threaded Locking Hole (8163-35-0XX).

Note: If inserting a 3.5 mm Multi-Directional Screw in threaded hole with a F.A.S.T. Guide® insert, then first remove the F.A.S.T. Guide® insert before commencing the technique. Additionally, note that the Torque Limiting Handle should not be used.

Insert the 2.7 mm end of the 2.0/2.7 mm Drill Guide (9399-99-435) into the plate hole and angle the drill as needed within an arc of 15 degrees (Figure 34). Drill through both cortices with the 2.7 mm Drill Bit (2142-27-070) (Figure 35).

Measure the drilled hole with the Small Fragment Depth Gauge (2142-35-100) by taking a direct reading from the LOCK line (Figure 36) and insert the appropriate length 3.5 mm Multi-Directional Screw with the 2.2 mm Square Driver (8163-01-000) coupled to the Ratchet Handle (8261-66-000) (Figure 37).

# A.L.P.S. Distal Fibula Plating System

## Ordering Information

### Anatomic Fibula Locking Plates:

	Orientation	Holes	Length
8162-06-003	Left	3	95 mm
8162-06-004	Left	4	109 mm
8162-06-006	Left	6	139 mm
8162-06-008	Left	8	169 mm
8162-06-010	Left	10	199 mm
8162-07-003	Right	3	95 mm
8162-07-004	Right	4	109 mm
8162-07-006	Right	6	139 mm
8162-07-008	Right	8	169 mm
8162-07-010	Right	10	199 mm

### Fibula Composite Locking Plates:

	Orientation	Holes	Length
8162-04-006	Bilateral	6	77 mm
8162-04-007	Bilateral	7	92 mm
8162-04-008	Bilateral	8	103 mm
8162-04-010	Bilateral	10	133 mm
8162-04-012	Bilateral	12	164 mm
8162-04-014	Bilateral	14	193 mm

---

**Screws:**

**2.7 mm Cortical Screws, Locking 8163-27-0XX**

10 – 50 mm in 2 mm increments

**2.7 mm Cortical Screws, Non-Locking 8140-27-0XX**

10 – 50 mm in 2 mm increments

50 – 70 mm in 5 mm increments

**3.5 mm Cortical Screws, Locking 8161-35-0XX**

10 – 60 mm in 2 mm increments

60 – 70 mm in 5 mm increments

**3.5 mm Multi-Directional Screws, Locking 8163-35-0XX**

10 – 60 mm in 2 mm increments

**3.5 mm Low Profile Cortical Screws, Non-Locking 1312-18-0XX**

10 – 50 mm in 2 mm increments

50 – 70 mm in 5 mm increments

**3.5 mm Cortical Screws, Non-Locking 8150-37-0XX**

10 – 50 mm in 2 mm increments

50 – 70 mm in 5 mm increments

**4.0 mm Cancellous Screws, Full Thread, Locking 8161-40-0XX**

10 – 50 mm in 2 mm increments

50 – 70 mm in 5 mm increments

**4.0 mm Cancellous Screws, Full Thread, Non-Locking 8153-41-0XX**

10 – 50 mm in 2 mm increments

50 – 70 mm in 5 mm increments

**4.0 mm Cancellous Screws, Partial Thread, Non-Locking 8155-40-0XX**

14 – 30 mm in 2 mm increments

30 – 70 mm in 5 mm increments

**4.0 mm Cannulated Cancellous Screws, Partial Thread, Non-Locking 14376-XX**

10 – 50 mm in 2 mm increments

50 – 70 mm in 5 mm increments





## **Screws, Plates, Intramedullary Nails, Compression Hip Screws, Pins and Wires**

### **Important:**

This Essential Product Information does not include all of the information necessary for selection and use of a device. Please see full labeling for all necessary information.

### **Indications:**

The use of metallic surgical appliances (screws, plates, intramedullary nails, compression hip screws, pins and wires) provides the orthopaedic surgeon a means of bone fixation and helps generally in the management of fractures and reconstructive surgeries. These implants are intended as a guide to normal healing, and are NOT intended to replace normal body structure or bear the weight of the body in the presence of incomplete bone healing. Delayed unions or nonunions in the presence of load bearing or weight bearing might eventually cause the implant to break due to metal fatigue. All metal surgical implants are subjected to repeated stress in use, which can result in metal fatigue.

### **Contraindications:**

Screws, plates, intramedullary nails, compression hip screws, pins and wires are contraindicated in: active infection, conditions which tend to retard healing such as blood supply limitations, previous infections, insufficient quantity or quality of bone to permit stabilization of the fracture complex, conditions that restrict the patient's ability or willingness to follow postoperative instructions during the healing process, foreign body sensitivity, and cases where the implant(s) would cross open epiphyseal plates in skeletally immature patients.

### **Additional Contraindication for Orthopaedic Screws and Plates only:**

Cases with malignant primary or metastatic tumors which preclude adequate bone support or screw fixations, unless supplemental fixation or stabilization methods are utilized.

### **Additional Contraindication for Retrograde Femoral Nailing:**

A history of septic arthritis of the knee and knee extension contracture with inability to attain at least 45° of flexion.

### **Additional Contraindications for Compression Hip Screws only:**

Inadequate implant support due to the lack of medial buttress.

### **Warnings and Precautions:**

Bone screws and pins are intended for partial weight bearing and non-weight bearing applications. These components cannot be expected to withstand the unsupported stresses of full weight bearing.

### **Adverse Events:**

The following are the most frequent adverse events after fixation with orthopaedic screws, plates, intramedullary nails, compression hip screws, pins and wires: loosening, bending, cracking or fracture of the components or loss of fixation in bone attributable to nonunion, osteoporosis, markedly unstable comminuted fractures; loss of anatomic position with nonunion or malunion with rotation or angulation; infection and allergies and adverse reactions to the device material. Surgeons should take care when targeting and drilling for the proximal screws in any tibial nail with oblique proximal screws. Care should be taken as the drill bit is advanced to penetrate the far cortex. Advancing the drill bit too far in this area may cause injury to the deep peroneal nerve. Fluoroscopy should be used to verify correct positioning of the drill bit.

### **Additional Adverse Events for Compression Hip Screw only:**

Screw cutout of the femoral head (usually associated with osteoporotic bone).

**Note: Do NOT remove F.A.S.T. Guide® inserts prior to sterilization.**

All trademarks herein are the property of Biomet, Inc. or its subsidiaries unless otherwise indicated.

This material is intended for the sole use and benefit of the Biomet sales force and physicians. It is not to be redistributed, duplicated or disclosed without the express written consent of Biomet.

For product information, including indications, contraindications, warnings, precautions and potential adverse effects, see the product labeling.



**One Surgeon. One Patient.®**

P.O. Box 587, Warsaw, IN 46581-0587 • 800.348.9500 x 1501

©2012 Biomet Orthopedics • biomet.com

Form No. BMET0004.0 • REV053112